

Power MIG[®] 180C

Power MIG[®]. The Professional's ChoiceSM.

Whether you're a farmer or a fabricator, an autobody shop or a backyard mechanic, the Power MIG[®] 180C will help you get the job done! It's a portable MIG welder designed for use with industrial 240 volt input power, so you can weld on thicker material—up to 5mm with MIG welding and 12mm with gas-less flux-cored welding.

The Power MIG[®] 180C features continuous voltage control which makes tuning in the perfect setting a breeze. It is ideal for critical applications where precise adjustment is required.

Lincoln[®] Diamond Core Technology[™] and the rugged industrial drive system will make it easy to get great results on steel, stainless or aluminum. Compare performance, features and price. . . you'll settle on Power MIG[®]. The Professional's Choice[™]!

Processes

MIG, Flux-Cored



Output



Input



Advantage Lincoln

Superior Arc Performance:

- **Exclusive Diamond Core Technology** delivers an outstanding arc you notice immediately compared to competitive models:
 - Great arc starts make getting started easy.
 - Wide voltage 'sweet spot' gives you a very forgiving arc, so setting controls is a snap.
 - Extremely low spatter reduces clean-up.
 - Outstanding aluminum & stainless performance, not just mild steel.
- **Wide 30 – 180 amp welding output range** is the highest output in its class – use 0.6mm wire on the thinnest sheet metal up to 1.2mm flux-cored wire for thick plate.
- **MIG weld 0.5mm up through 5mm** sheet metal in a single pass. Weld up to 12mm steel using self-shielded Lincoln[®] Innershield[®] wires (FCAW-S).

Professional Features:

- **Industrial Cast Aluminum Drive** features:
 - Dual gear-driven drive rolls for positive traction.
 - Patented split wire guides for optimal wire alignment.
 - Brass-to-Brass gun connections for enhanced connectivity.
 - Large industrial closed-design drive motor for improved torque and trouble-free performance.

- **Spool Gun Ready** – add the optional Magnum[®] 100SG spool gun for reliable operation at the high wire feed speeds aluminum welding demands. No expensive add on modules required.
- **No Hassle Tool-less Design** – for wire spool mounting, wire drive service and polarity changes.
- **Get More, Do More** – Start out with more contact tips, nozzles drive rolls and wire for MIG or flux-cored welding with our ready-to-weld[™] package.
- **Innovative contact tip, drive roll and nozzle storage** keeps all your consumables close at hand.
- **Electrically 'cold' electrode** provides an added measure of operator safety.

Superb Quality:

- **Patent-pending Power Chassis[™]** channels airflow to cool power systems, structurally secures key components and traps wires and cables to avoid unnecessary abrasion.
- **Toughest PC Board Protection in the industry** – 'Potted' to seal sensitive components from the environment, 'trayed' in a tough plastic tray to add rigidity and shock resistance.
- **Backed by Lincoln Electric's 3-year warranty including parts and labour.**

TECHNICAL SPECIFICATIONS

Product Name	Product Number	Input Power	Rated Output Current/Voltage/Duty Cycle	Rated Input	Output Range	Dimensions H x W x D mm	Net Weight kg
Power MIG [®] 180C	K2668-1	240/1/50/60	130A/17V/30% 130A/20V/30%	10.7A	30-180 Amps DC 1.3-12.7 m/min Max. OCV:33	357 X 258 X 472	30



Publication E7.24 9/07

Web Update 2/07
www.lincolnelectric.com.au

A CLOSER LOOK

SUPERIOR ARC PERFORMANCE

Diamond Core Technology™ delivers a superior arc across the entire welding range.



Thin Sheet Metal Autobody Work



Home Projects



Repair Work

PROFESSIONAL WIRE DRIVE

Enhanced Quality

1. Brass Gun Connection Enhances Connectivity
2. Rigid Cast Aluminum Drive Aids Wire Alignment
3. Patented Split Wire Guide Reduces Tangles
4. Dual Gear-Driven Drive Rolls Deliver Positive Traction

Easy to Use

5. Easy Turn Tension Adjustment
6. Tool-less Quick Lock Drive Roll Changeover

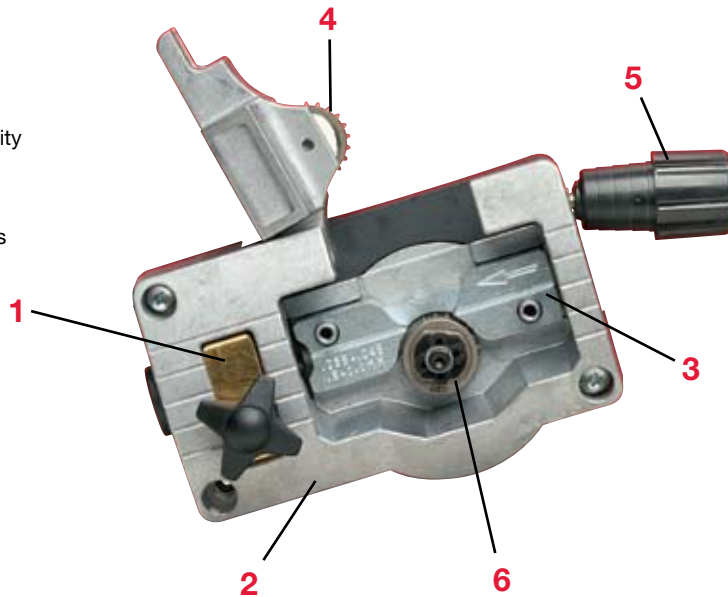

PRECISION ALUMINUM WELDING

Magnum® 100SG Spool Gun

Our low-priced spool gun is your most reliable aluminum feeding solution.



Great For Projects or Repair



Complete Kit. No Bulky Module Required.
Order K2532-1

A CLOSER LOOK

WHAT'S INCLUDED

Power MIG® 180C (K2668-1) includes:
Gun

- Magnum® 100L gun and 3.0 m cable assembly with brass gun connection and 4-pin MS-Type connection for trigger control (K530-6)
- 0.6 mm Contact Tips (Qty. 3) (KP11-25)
- 0.9 mm Contact Tips (Qty. 3) (KP11-35)
- Gasless Nozzle for Innershield® welding (KP1939-1)
- Gas Nozzle for MIG welding (KP21-50-F)

Drive

- Spindle Adapter for 5kg Spools (M15445-R)
- 1.2 mm Wire Diameter Wire Guide (KP2531-2)
- 0.6-0.9 mm Wire Diameter Wire Guide (KP2531-1)
- 0.6 mm Wire Diameter Drive Roll for MIG welding (KP2529-1)
- 0.9 mm Wire Diameter Drive Roll for MIG welding (KP2529-2)
- 0.8-1.2 mm Wire Diameter Knurled Drive Roll for Flux-Cored welding (KP2529-3)

Shielding Gas Apparatus

- Gas Regulator and 1.3 m Hose for use with argon blend gases

Welding Wire

- 0.90 kg Spool of 0.6 mm diameter SuperArc® L-56® premium MIG wire
- 0.45 kg Spool of 0.9 mm diameter Innershield® NR®-211-MP flux-cored wire

Other

- Work Clamp and 3.0 m Cable
- Instruction Manual (IM-890)
- How to Use DVD
- Learn to Weld Manual (LWTW1)

WHAT'S INCLUDED



GENERAL ACCESSORIES



PERFORMANCE PLUS

Power MIG® 180C Welding Capabilities

Process	Wire Dia.	Wire Diameter													
		0.5 mm	0.6 mm	0.8 mm	1.0 mm	1.6 mm	2.0 mm	2.5 mm	3.2 mm	5 mm	6 mm	8 mm	9.5 mm	12 mm	
Flux-Cored Welding – Steel	0.8 mm														
	0.9 mm														
	1.2 mm														
MIG Welding – Steel	0.6 mm														
	0.8 mm														
	0.9 mm														
MIG Welding – Aluminum	0.9 mm														

(1) Single Pass.
(2) Multiple Pass.



DRIVE ROLLS AND WIRE GUIDES

Product Number	Wire Diameter mm	Type/Process
Drive Rolls		
KP2529-1	0.6-0.7	Smooth/MIG
KP2529-2	0.9	Smooth/MIG
KP2529-3	0.8-1.1	Knurled/Flux-Cored
Inner Wire Guides		
KP2531-1	.0.6-0.9	All
KP2531-2	1.1	All

RECOMMENDED OPTIONS

GENERAL OPTIONS



Welding Cart

Full-featured cart is designed to store and transport a welder, E size gas cylinder, welding cables and accessories. Includes an angled top shelf for easy access to welder controls, a lower tray for added storage space, a sturdy handle and a convenient cable wrap hanger.

Order K2275-1



Utility Cart

Heavy duty cart stores and transports welder, G size shielding gas cylinder, welding cables and accessories. Includes stable platforms for welder and gas bottle platform, lower tray for added storage capacity and adjustable height handle.

Order K520



Small Canvas Cover

Protect your welder when not in use. Made from attractive red canvas that is flame retardant, mildew resistant and water repellent. Includes a convenient side pocket to hold your welding torch or gun.

Order K2377-1

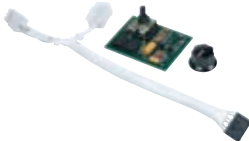

Spot Timer Kit

This timer allows you to set a fixed weld time of up to 10 seconds that is initiated when you pull the gun trigger. Ideal for making consistent spot welds on thin sheet metal.

Order K2525-1



WIRE FEEDER OPTIONS

Aluminium Kit

Magnum® 100SG Spool Gun

Designed to easily feed 102 mm diameter 0.45 kg spools of 0.8 mm or 0.9 mm diameter Alumig® aluminum MIG wire. Includes gun, adapter kit, 0.9 mm contact tips (qty. 3), gas nozzle, and a 0.45 kg spool of SuperGlaze® 4043 0.9 mm MIG wire. Packaged in a convenient carrying case.

Order K2532-1



1.2 mm Innershield® Kit

Includes everything required to weld with 1.2 mm Innershield® self-shielded flux-cored wire. Includes an 0.9-1.2 mm Magnum® 100L gun liner, a 1.2 mm contact tip, a gasless nozzle, knurled drive roll, 1.2 mm inner wire guide and a 4.5 kg spool of 1.2 mm Innershield® NR®-212 wire.

Order K2528-1



Welding Fume Extractors

Lincoln offers a wide variety of welding fume extraction environmental system solutions, ranging from portable systems easily wheeled around the shop to shop-wide central systems servicing many dedicated welding stations.

Request Publication E13.40

CUSTOMER ASSISTANCE POLICY

The business of The Lincoln Electric Company® is manufacturing and selling high quality welding equipment, consumables, and cutting equipment. Our challenge is to meet the needs of our customers and to exceed their expectations. On occasion, purchasers may ask Lincoln Electric® for advice or information about their use of our products. We respond to our customers based on the best information in our possession at that time.

Lincoln Electric® is not in a position to warrant or guarantee such advice, and assumes no liability, with respect to such information or advice. We expressly disclaim any warranty of any kind, including any warranty of fitness for any customer's particular purpose, with respect to such information or advice. As a matter of practical consideration, we also cannot assume any responsibility for updating or correcting any such information or advice once it has been given, nor does the provision of information or advice create, expand or alter any warranty with respect to the sale of our products.

Lincoln Electric® is a responsible manufacturer, but the selection and use of specific products sold by Lincoln Electric® is solely within the control of, and remains the sole responsibility of the customer. Many variables beyond the control of Lincoln Electric® affect the results obtained in applying these types of fabrication methods and service requirements.

Subject to Change - This information is accurate to the best of our knowledge at the time of printing. Please refer to www.lincolnelectric.com for any updated information.